



SCIGATE AUTOMATION (S) PTE LTD

No.1 Bukit Batok Street 22 #01-01 Singapore 659592

Tel: (65) 6561 0488

Fax: (65) 6562 0588

Email: sales@scigate.com.sg

Web: www.scigate.com.sg

Business Hours: Monday - Friday 8.30am - 6.15pm

Device/PLC Connection Manuals



About the Device/PLC Connection Manuals

Prior to reading these manuals and setting up your device, be sure to read the "Important: Prior to reading the Device/PLC Connection manual" information. Also, be sure to download the "Preface for Trademark Rights, List of Units Supported, How to Read Manuals and Documentation Conventions" PDF file. Furthermore, be sure to keep all manual-related data in a safe, easy-to-find location.





2.22 ORIM VEXTA

2.22.1 System Structure

The following describes the system structure for connecting the GP to ORIM VEXTA PLCs.

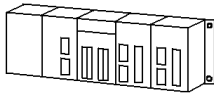
Reference The Cable Diagrams mentioned in the following tables are listed in the section titled "2.22.2 Cable Diagrams".

■ E1 Series (Link I/F)

CPU	Link I/F	Cable Diagram	GP
			
CPU11	MM01	RS232C (Cable Diagram 1)	GP Series

2.22.2 Cable Diagrams

The cable diagrams shown below and the cable diagrams recommended by ORIM VEXTA may differ, however, regardless of these differences, using Digital's recommended diagrams will not cause any operation problems.

Cable Diagram 1 (RS-232C)

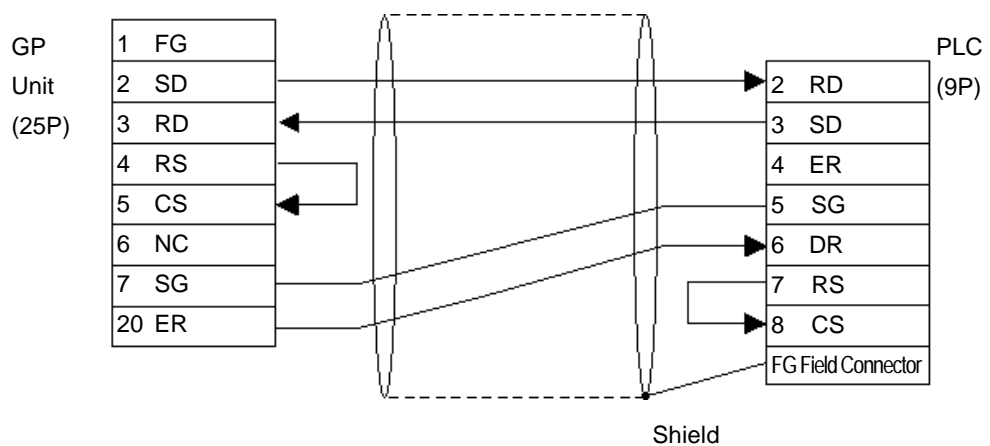









- You will need to make your own cable.
- When using an RS-232C cable, the cable must be no longer than 15 meters.

2.22.3 Supported Devices

The following describes the range of devices supported by the GP.

■ **E1 Series**

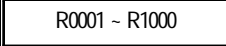
 Setup System Area here.

Device	Bit Address	Word Address	Particulars	
Input Register (I)	I000100 ~ I000815	I0001 ~ I0008		L/H
ON Event Input Register(IU)	IU00100 ~ IU00815	IU001 ~ IU008	*2	
OFF Event Input Register(ID)	ID00100 ~ ID00815	ID001 ~ ID008	*2	
Output Register(O)	O000100 ~ O000815	O0001 ~ O0008		
Analog Input Register(AD)	-----	AD001 ~ AD008	 *2	
Analog Output Register(DA)	-----	DA001 ~ DA008		
Position Register (M)	M000100 ~ M010031	M0001 ~ M100	*3	H/L
Speed Register Low(SL)	-----	SL001 ~ SL100	 *3	
Speed Register High(SH)	-----	SH001 ~ SH100	 *3	
Speed Register Raise(SR)	-----	SR001 ~ SR100	 *3	
Speed Register Decrease(SD)	-----	SD001 ~ SD100	 *3	
Universal Register(R)	R000100 ~ R100015	 R0001 ~ R1000		L/H
Universal Double-Length Register(RD)	RD00100 ~ RD50031	RD001 ~ RD500	*3	
Base Resister (B)	B000000 ~ B000915	B0000 ~ B0009		
Current Motor Position(MP)	-----	MP001~MP008	 *3 *2	H/L
Current Motor Status(MP)	MS00100 ~ MS00815	MS001 ~ MS008	*2	L/H
SY Register(SY)	SY00100 ~ SY10015	SY001 ~ SY100	*1 *2	

*1 For further information about SY register, refer to ORIM VEXTA's Motion Controller E1 Series Operation manual.

*2 Data cannot be written to here.

*3 This device is 32 bit.

2.22.4 Environment Setup

The following lists Digital's recommended PLC and GP communication settings.

■ E1 Series

GP Setup		PLC Setup	
Baud Rate	9600 bps ^{*1}	Baud Rate	9600 bps
Data Length	8 bits	Mode	8 bits
Stop Bit	1 bit	Stop/Data	1 bit
Parity Bit	None	Parity Bit	None
Data Flow Control	ER Control	---	ER Control
Communication Format (RS-232C)	RS-232C	Communication Format (RS-232C)	RS-232C (fixed)
Station No.	1 (fixed)	Station No.	---
---		Checksum	Yes
---		Designate Termination Code	Yes
---		Protection	No

*1 The maximum baud rate is 19200 bps.

